

FACE to FACE WITH THE NEW WILLYS EIGHT

Retail Sales Manager's Film Service

COPYRIGHTED 1930 BY WILLYS-OVERLAND, INC.

One in a series of original filmstrips preserved for their historical value and presented to the members of the [Willys Overland Knight Registry](#)

Assembled November 2000 by Spence Fowler
(member #4536)

sdf@att.net

<http://sdf.home.att.net>



FACE to FACE
WITH THE
NEW
WILLYS EIGHT



Motor car beauty of a
new unusual kind is
revealed in the Willys eight.
Yet beauty, striking as it is,
is but one of the features
of this new car.



The outstanding performance of the new 8-80 is a direct result of quality that has been built into it. When you examine this car, and drive it, you will instantly appreciate why it is establishing new standards in the inexpensive, eight cylinder field.



efore we show you the
cardinal features of
this new eight, permit us to
acquaint you with the
tremendous organization
back of it.

WILLYS
8
YE



Here is one of the great Willys Overland Factories whose facilities and volume are largely responsible for the superb 8-80 at its moderate price.

5



The new Willys Eight is announced only after painstaking experiments and exhaustive tests which have proved it superior in its price class. ~ ~ ~







All these tests have proved
Willys superiority over
other eights in smoothness,
speed, pick-up, hill climb-
ing and —
gas economy.





From the high distinctive radiator to the balanced sweep of the rear quarters the Willys Eight expresses style and character of custom built tendencies.



ut before we show you
 the smartness of the
body designs of this new
car let us visualize its hidden
value --- the things which will
deliver countless miles of
thrilling performance.

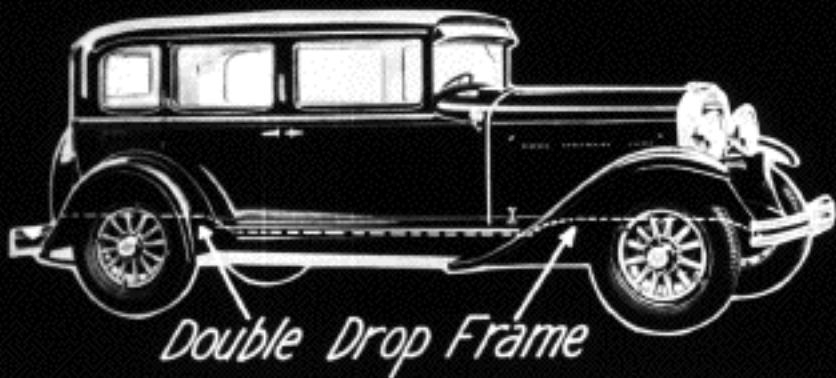

The double drop frame for example gives the Willys 8 sleek low-to-the-ground smartness. It increases road stability and driving ease at high speeds.

WILLYS
8

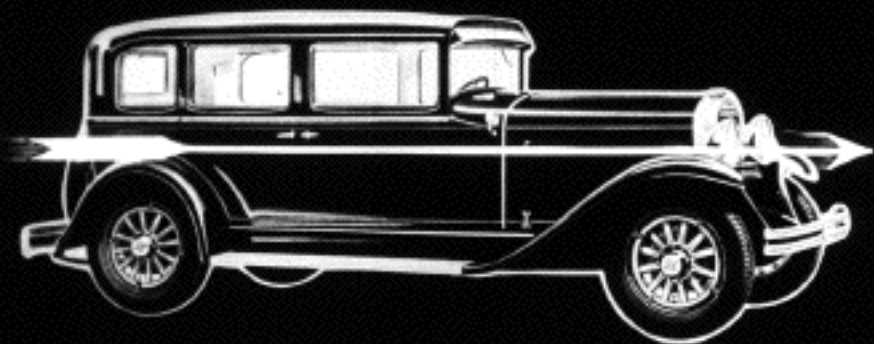

Every line, every curve, is proportioned to picture a promise of performance best likened to the flight of an arrow.



There is a dramatic
significance in the
name Willys '8'

8 cylinders
80 horsepower



Here is the 8 cylinder motor that places the Willys 8 among the fastest cars on the highways.

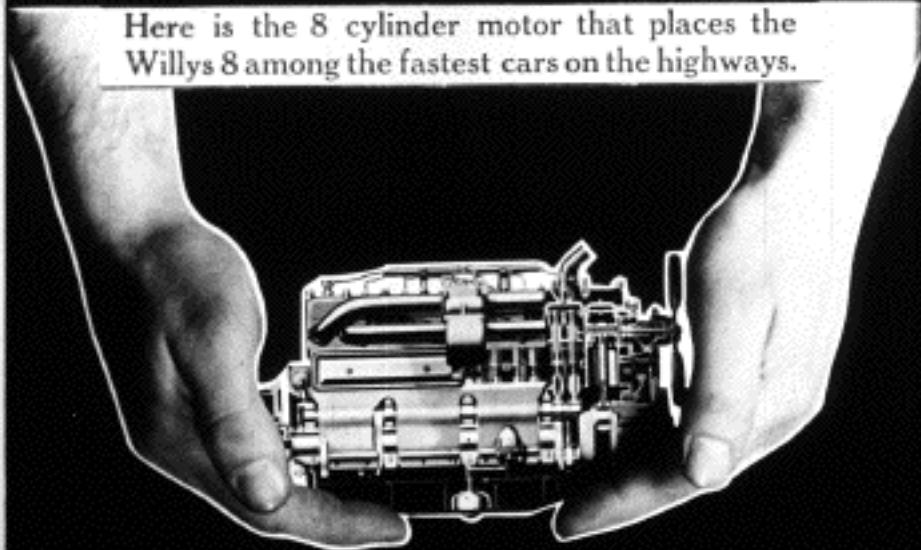

Here are a few things worthy of your consideration.

*Eight cylinders, 3 1/8 x 4",
Full Pressure Feed Lubrication,
Balanced and Counterbalanced
Crankshaft, Vibration Dampener,
Rubber Engine Mounting.*

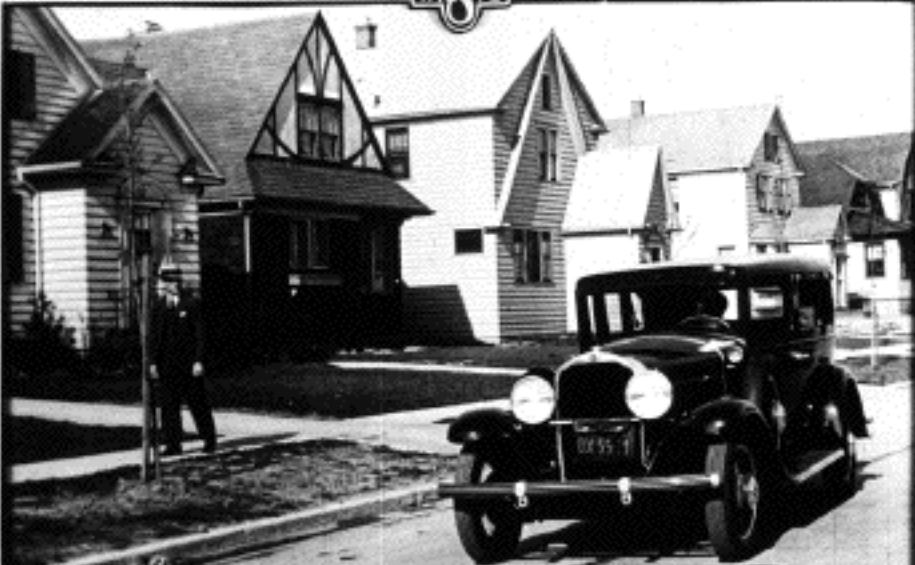

So smooth with its constantly overlapping power impulses you could stroll beside it as it idles along in high gear.

WILLYS
8
YE



And with its 80 horsepower, you can zoom along at more than a mile a minute in perfect comfort and maximum safety.

16



is a Year
of Eights
and —
the Willys '8' is the
Eight of the year!

W 8 YS

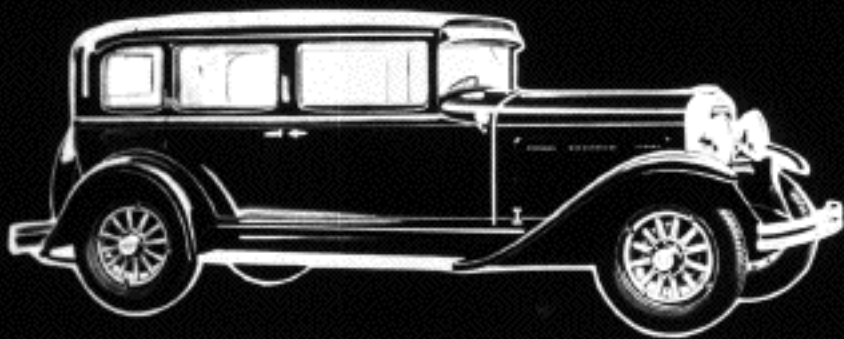

After many months of gruelling tests, this splendid car is our answer to the question, "When is Willys Overland going to announce an EIGHT?"



 Like every Willys -
Overland car, the
Willys '8' brings high qual-
ity at low cost thanks
to worldwide demand and
volume production.

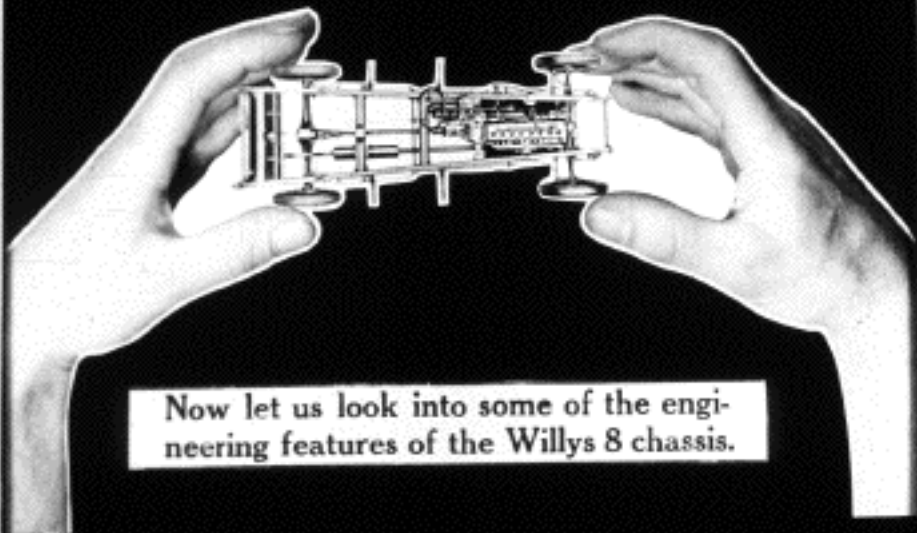

Now let us look into some of the engineering features of the Willys 8 chassis.

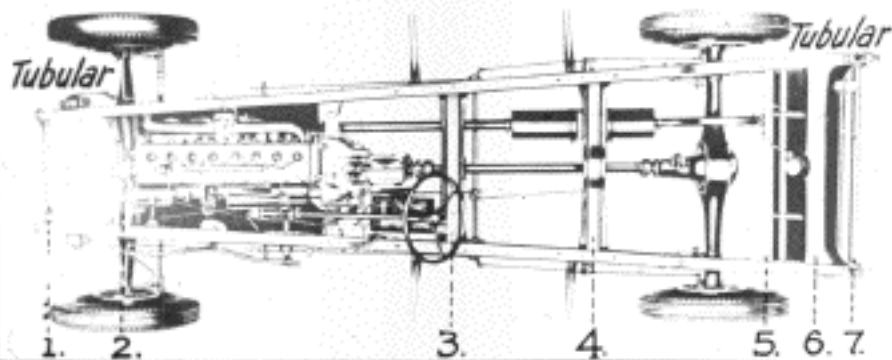

The Powerful Willys 8 has an unusually deep and rugged frame. 7 heavy cross members, two of them tubular, assure rigidity and strength.

The frame is a
double drop type, —
keeping the center of
gravity low to help the
car hug the road at its
high speeds.



Four wheel brakes
are internal
expanding and
fully enclosed.

-They are all
weather brakes affording
maximum safety.

WILLYS 8

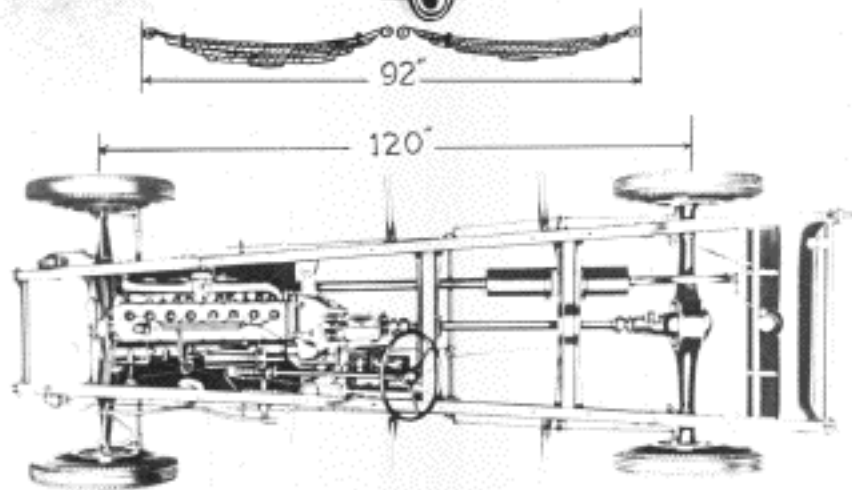

The Willys 8 rides on 92 inches of springs
- equal to 77% of the 120" wheelbase.

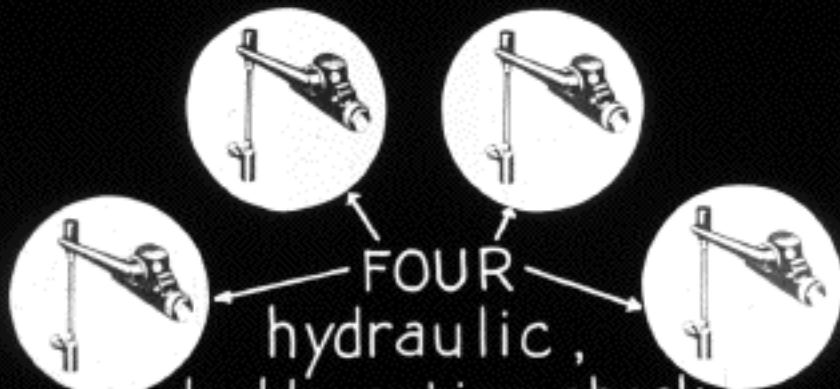

FOUR
hydraulic,
double acting shock
eliminators control every move-
ment of the springs.



Performance,
Style, Comfort,
Safety,

Economy,-

You get them all in
the Willys 8!



8 Cylinder Smoothness

Long High Hood

120" Wheelbase

Low wide running boards

Rugged Double Drop Frame

Chromium Finish metal

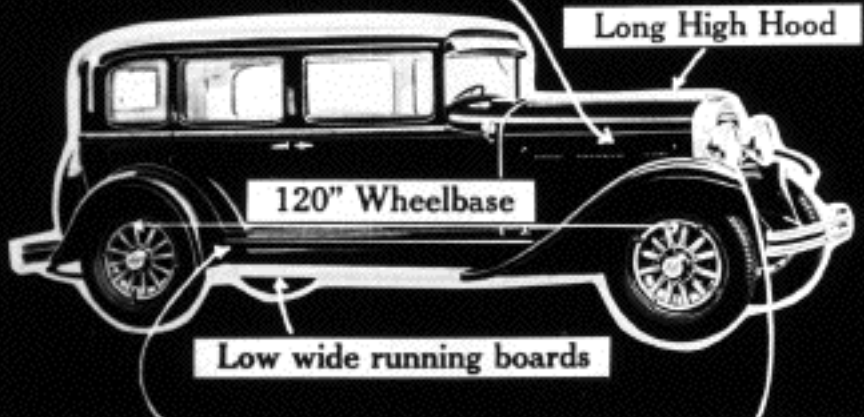



All nicety of detail that you would expect, - Fine Fabrics, Curtains, Foot Rest, Arm Rest, Silk Assist Cords, **EVERYTHING FOR LUXURIOUS COMFORT.**

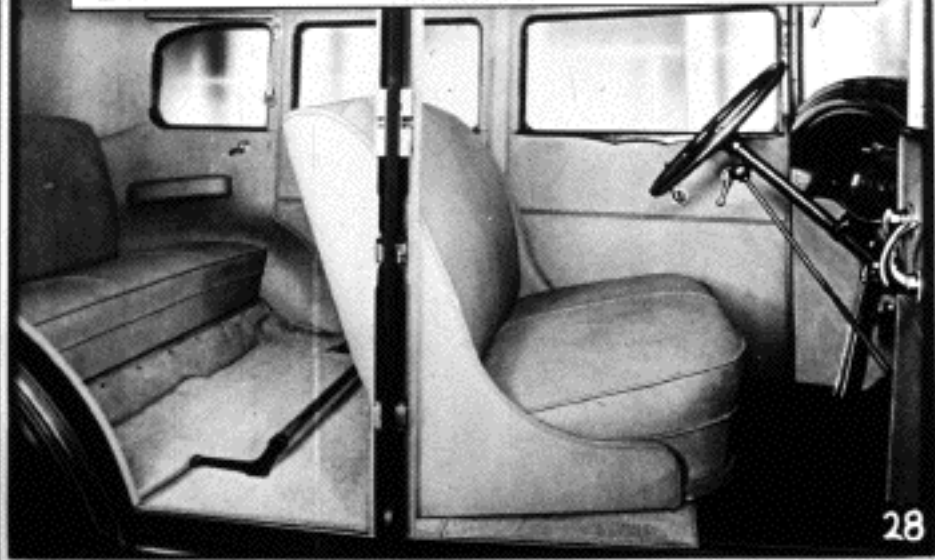

WILLYS 8

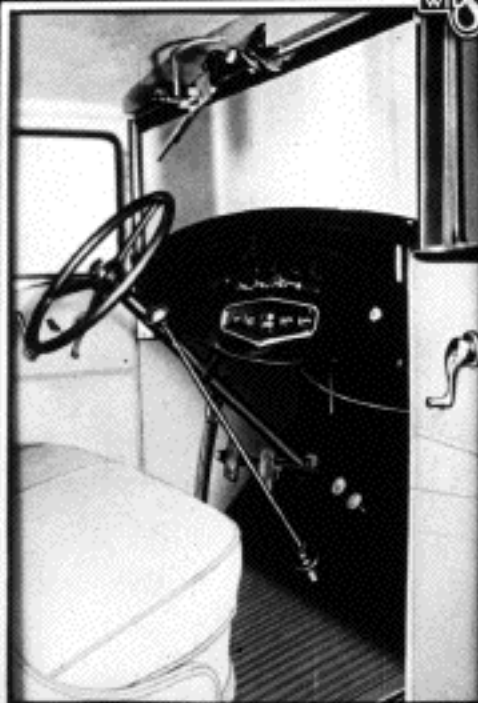

In the Willys 8
special
attention
has been
paid to
driving
convenience.



Adjustable Seat — Finger Tip Control

Adjustable Steering Post

Indirect Lighting for Gauges.

Narrow Corner Posts—Ample Leg Room

Convenient Gear Shift

Windshield Mono Control

You'll enjoy not only riding but

DRIVING!



Pleasing design
is carried out
even to the
shield
covering
gasoline tank
and frame.



 And speaking of the gasoline tank, ---if you are a crank on miles per gallon you will be surprised at Willys 8 ECONOMY.

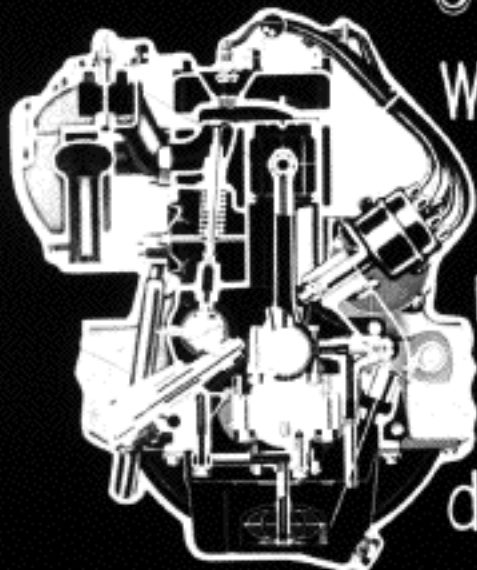

With Willys 8
Carburetion,
manifolding
and valve
design, maximum
economy has been achieved.



Good mileage
is a sure
sign of
Good Design.

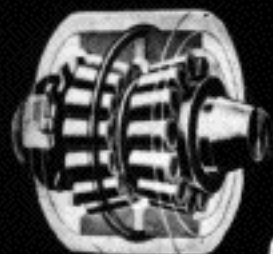

The Willys 8 is "Jeweled" throughout with Timken Bearings, recognized for their superiority.



nce you experience
the thrill of Willys 8
Performance even our
most enthusiastic claims
will be confirmed.

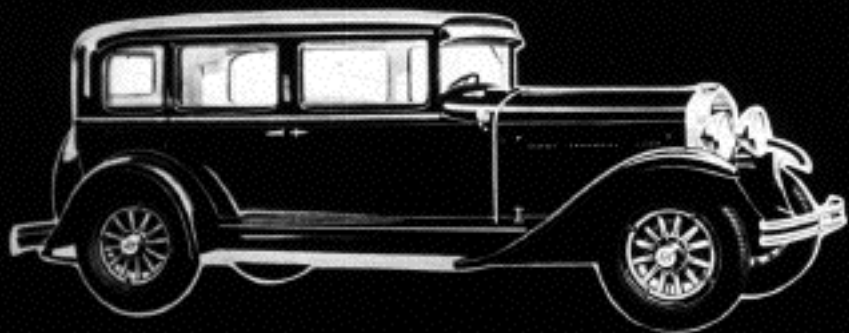

Whether you want a roomy
5 passenger family sedan —

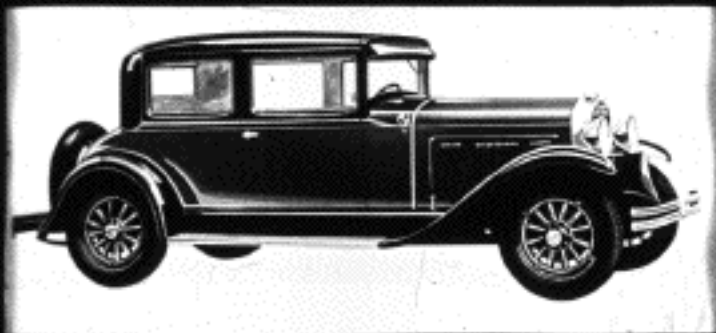

Or this delightfully
personalized Coupe.



The new
Willys eight
will satisfy
your
every
requirement.

COPYRIGHTED 1930 BY WILLYS-OVERLAND, INC.

The End
To rewind, start at this end dull side out holding film by edges. Be sure to keep fingers off dull side of film.



A production of
THE VISUAL DEMONSTRATION SYSTEM, Inc.
259 Delaware Ave.
Buffalo, N.Y.

Retail Sales Manager's Film Service.