

The Mechanical Story only
WILLYS KNIGHT Can Tell
Retail Sales Manager's Film Service
COPYRIGHTED 1930 BY WILLYS-OVERLAND, INC.

One in a series of original filmstrips preserved for their historical value and presented to the members of the **Willys Overland Knight Registry**

Assembled January 2002 by Spence Fowler
(member #4536)
sdf@att.net



THE MECHANICAL STORY
ONLY

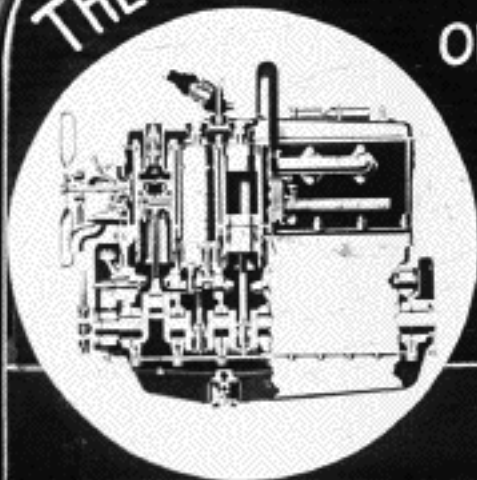

WILLYS
KNIGHT
CAN TELL.



There are just two kinds
of automobiles—those that
are Knight-motored and
those that aren't.

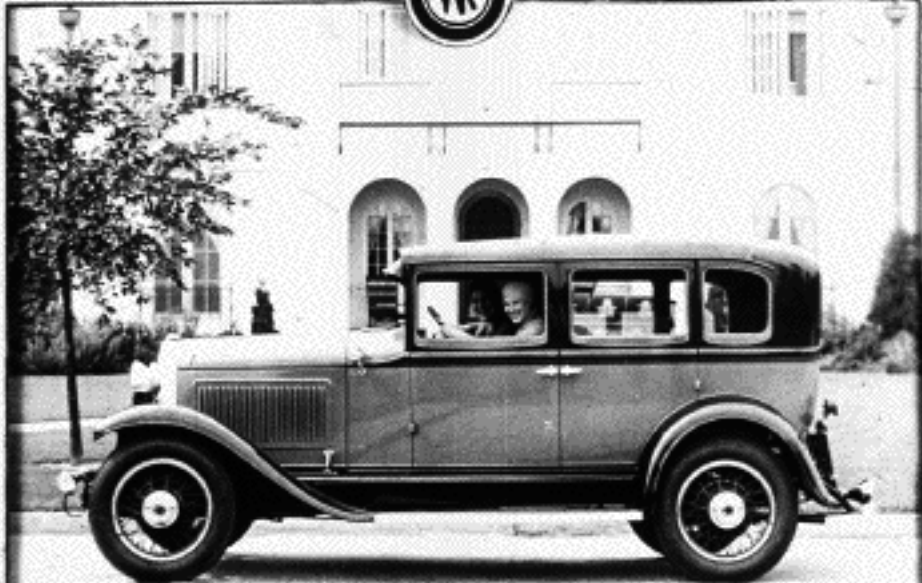

The distinguished appearance of the Willys Knight 70-B car does honor to its superlatively engineered chassis.

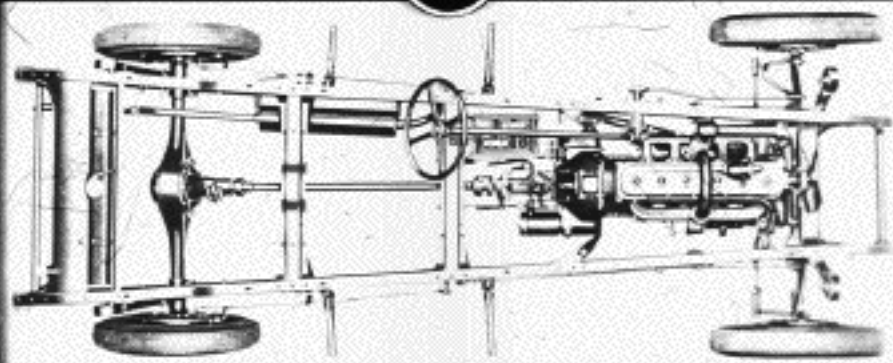

Here is the chassis which in silence, long life and upkeep economy is a fitting foundation for the Willys Knight motor.

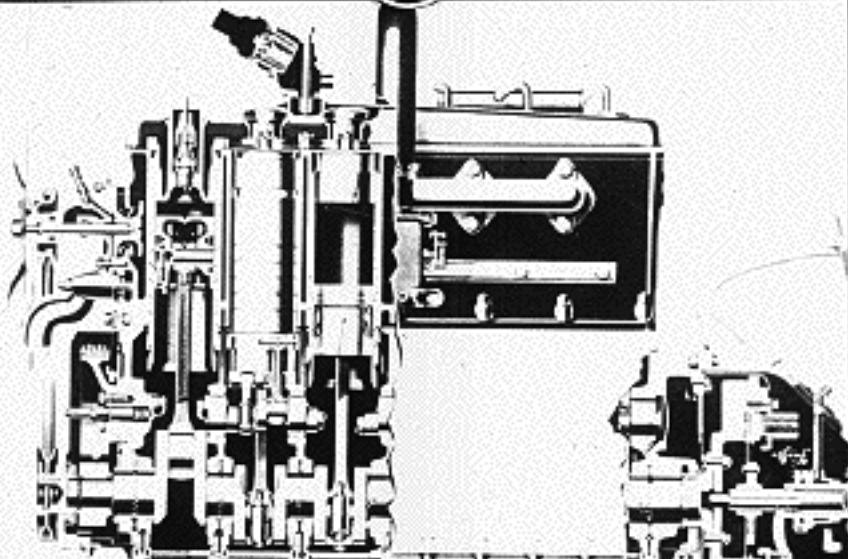

The exterior simplicity of the Willys Knight motor indicates the simplicity of its working parts.



It is an engineering
fact that when you
make it simpler --
you make it better.

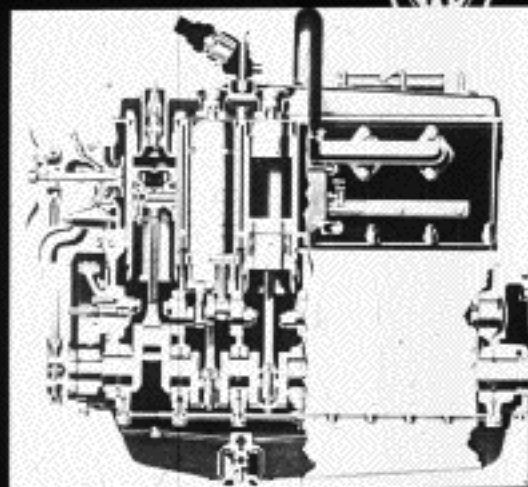

Willys Knight
Simplicity
Contributes
to-QUIETNESS,
LONG LIFE,
DEPENDABILITY.

FUEL ECONOMY, UPKEEP ECONOMY
and BRILLIANT PERFORMANCE.

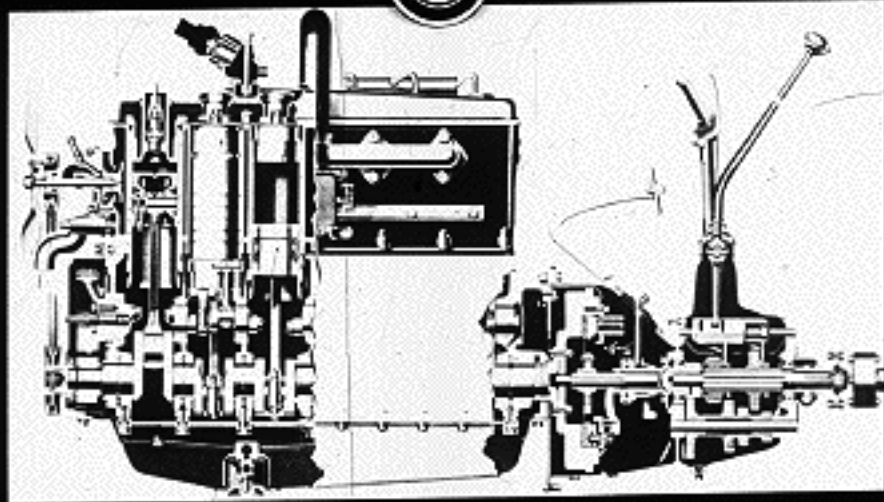

If the Willys Knight motor was made of glass, you would easily see its many exclusive engineering features. We will now show them to you part by part.....

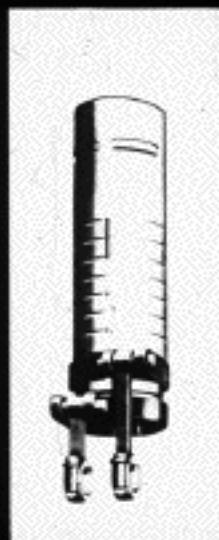

Here are the two simple sleeves which move quietly up and down, one within the other, in a protective film of oil.

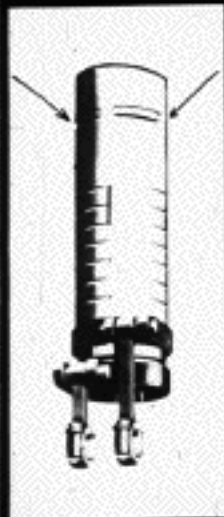

This shows the ports which open and close, taking the place of clattering valves which have to be ground and adjusted to maintain efficiency.

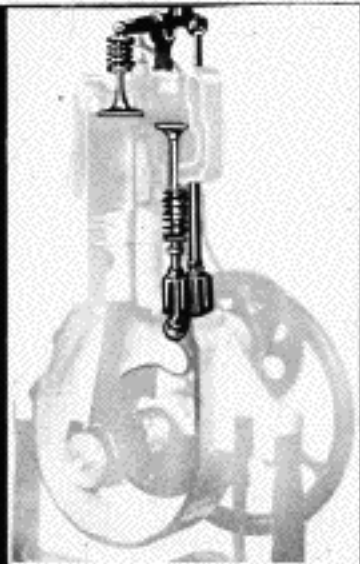

Compare the few working parts of the Knight sleeve valves with the numerous working parts of overhead valves, and don't forget to multiply by the number of cylinders.



The Willys-Knight spherical cylinder head evenly distributes the full force of the explosion directly downward against the piston.



Willys-Knight
sleeve valves assure
high uniform
compression at all times, at
all speeds, WITH ANY CAR.



MANUFACTURED UNDER LICENSE FROM
KNIGHT AMERICAN PATENTS COMPANY

BY
THE WILLYS-OVERLAND COMPANY
TOLEDO, OHIO, U. S. A.

PATENTED IN THE UNITED STATES AUG. 23-1910
SEPT. 9-1913 MARCH 24-1914 APRIL 20-1915
OTHER PATENTS PENDING

LICENSE NO

4025-43

MODEL

ENGINE NO

The advantages of double sleeve valves are available
ONLY in the Knight engine. They are patented.



The remarkable degree of quietness in operation found in the Willys-Knight engine is due to its being designed and built on a principle which employs only quiet mechanism.

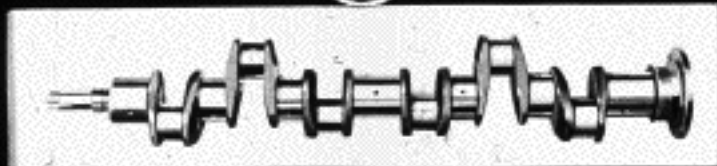

In addition to sleeve valves, the WILLYS-KNIGHT 70-B engine includes such costly features as the 7 bearing crankshaft.



Nelson type invar strut aluminum pistons matched within a fraction of an ounce give added brilliance to Willys Knight performance.

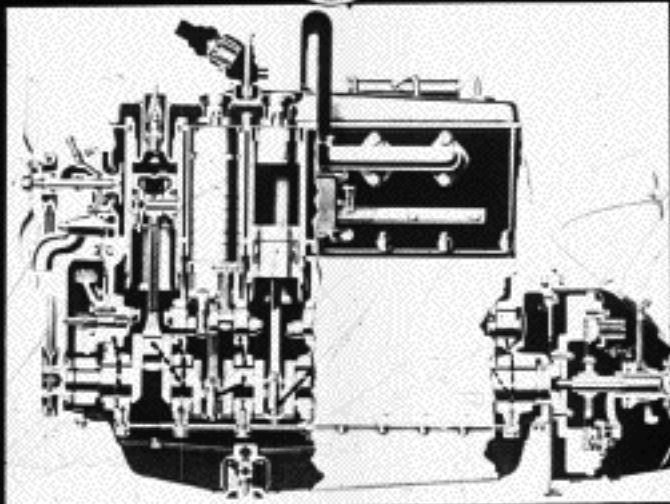

Pressure lubrication to all crankshaft, connecting rod and eccentric shaft bearings also maintains quietness and long life over the years.



The Willys-Knight carries its own "Oil Refinery" right with it, constantly keeping the oil at its highest lubricating value and sending crankcase dilution back for use as fuel.

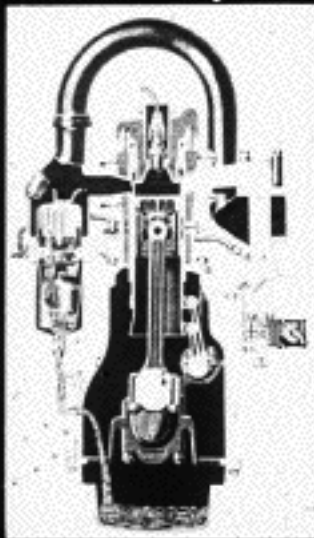



An automatic thermostat controls the motor temperature, assuring quick "warm up," smoothest operation and greatest fuel economy.



SO smooth ~
silent ~
powerful ~
driving your Willys-Knight
is as thrilling as coasting
down hill ALL THE TIME!

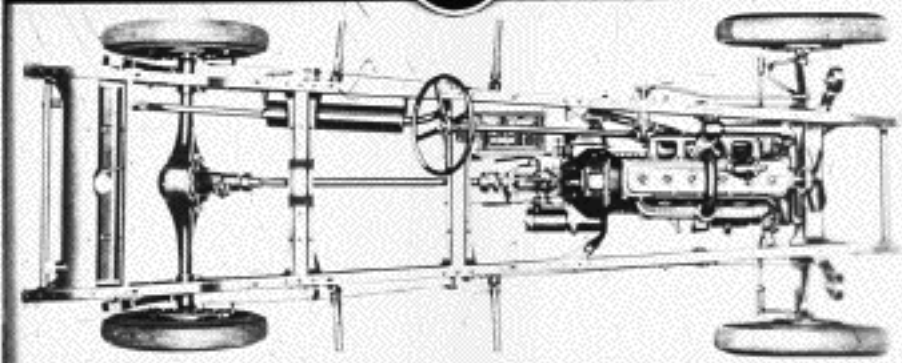

And so on, part by part, through—
out the Willys-Knight chassis, you
will discover engineering in keep-
ing with its marvelous motor.

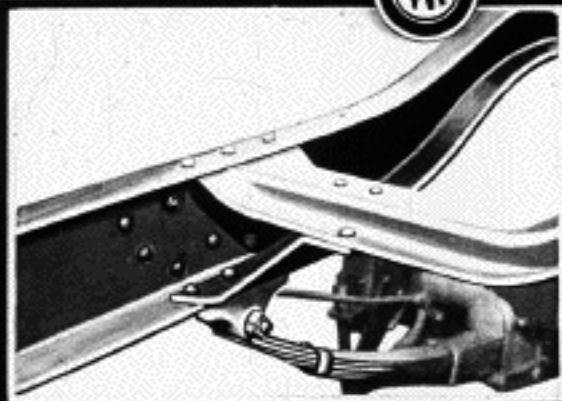

Strength,
rigidity,
freedom
from racking
for the life
of you car,—thanks to Willys-
Knight cross members, riveted
to both upper and lower flanges.

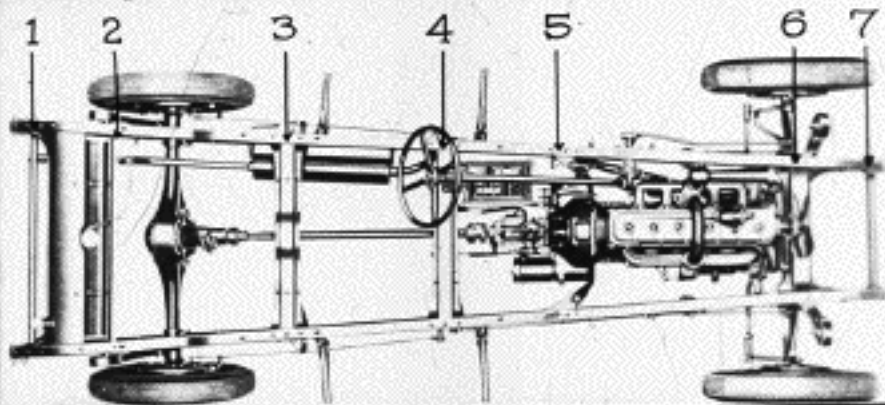

Upon the strength of the foundation on which your car is built depends the life and serviceability of your car. We honestly believe the 70-B chassis is the strongest frame in its class. We urge you to confirm this.



The silent Willys-Knight



has silent
self adjusting
self lubricating
Tryon
spring shackles.



The Willys-Knight rear axle is as quiet as the

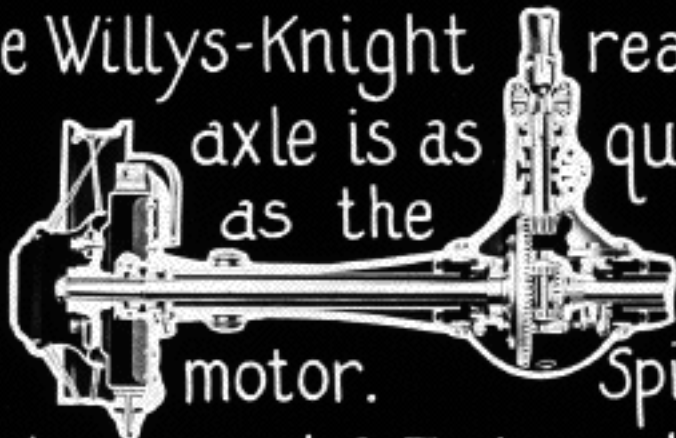

motor. Spiral bevel gears and 8 Timken roller bearings make it so and keep it so.



27

Four wheel Bendix brakes



let you enjoy

Willys

Knight

power and

speed with Safety.



Willys Knight positive
braking control is also
important. When driving in
dense traffic-good brakes
are more important than
good bumpers.



Efficient Shock Elim-
inators front and rear
are Standard equipment
to make it ride as
smoothly as it runs.

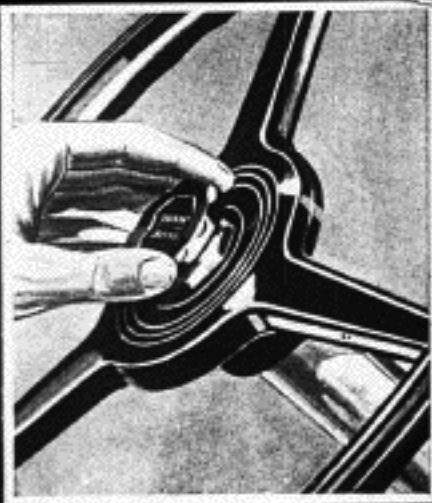

Convenience
and safety are
combined in the
Finger Tip Control
of starter, horn, lights and dimmer.

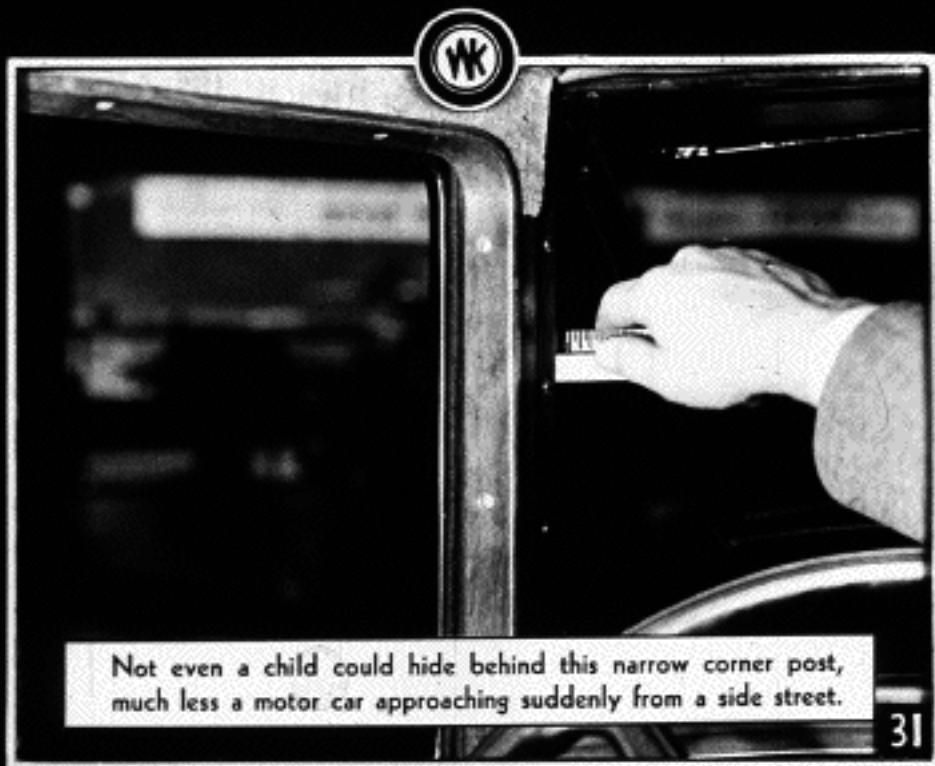

Not even a child could hide behind this narrow corner post, much less a motor car approaching suddenly from a side street.

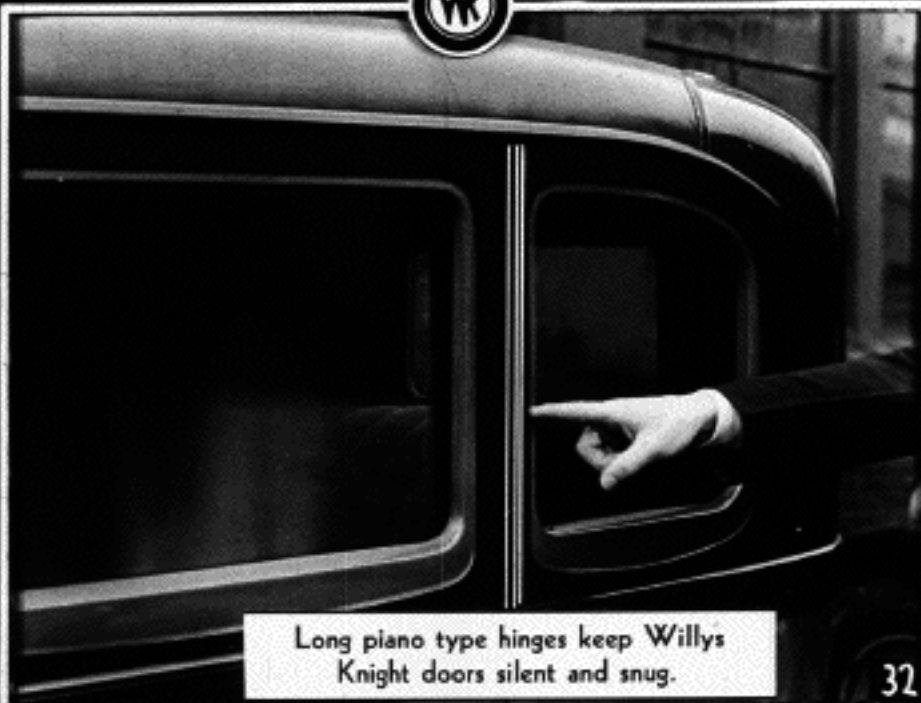

Long piano type hinges keep Willys Knight doors silent and snug.



Scientific insulation between fenders and body lets you enjoy not only a silent motor but a silent car.





Because of its recognized
superiority, many people
have the mistaken idea
that they can't afford a
Knight-motored car,
But ---



The tremendous resources and manufacturing facilities of the great Willys-Overland factory are making it possible for thousands of critical motorists to own their long-cherished WILLYS KNIGHT!





The worldwide success of the Willys-Knight 70-B is a dramatic example of a good article being its own best salesman.



And now that you have seen what the Willys
Knight is, let a ride show you what it DOES.





Remember as you drive —
there are just two kinds
of automobiles — those
that are

Knight - motored ,
- and those that aren't!

COPYRIGHTED 1930 BY WILLYS - OVERLAND, INC.

The End
To rewind, start at this end dull side out
holding film by edges. Be sure to keep fin-
gers off dull side of film.



A production of
THE VISUAL DEMONSTRATION SYSTEM, Inc.
259 Delaware Ave.,
Buffalo, N.Y.

Retail Sales Manager's Film Service.