

THERE'S MONEY in WHIPPET
and WILLYS 6 TRUCKS

Retail Sales Manager's Film Service

COPYRIGHTED 1930 BY WILLYS-OVERLAND, INC.

One in a series of original filmstrips preserved for their historical value and presented to the members of the

Willys Overland Knight Registry

Assembled January 2002 by Spence Fowler
(member #4536)

sdf@att.net



"There's Money in
WHIPPET and WILLYS 6
TRUCKS"



"THERE'S MONEY IN TRUCKS."

REMEMBER,

 - trucks are necessities, not luxuries -
to-day's business world
simply can't do business
without trucks.

2

"THERE'S MONEY IN TRUCKS."

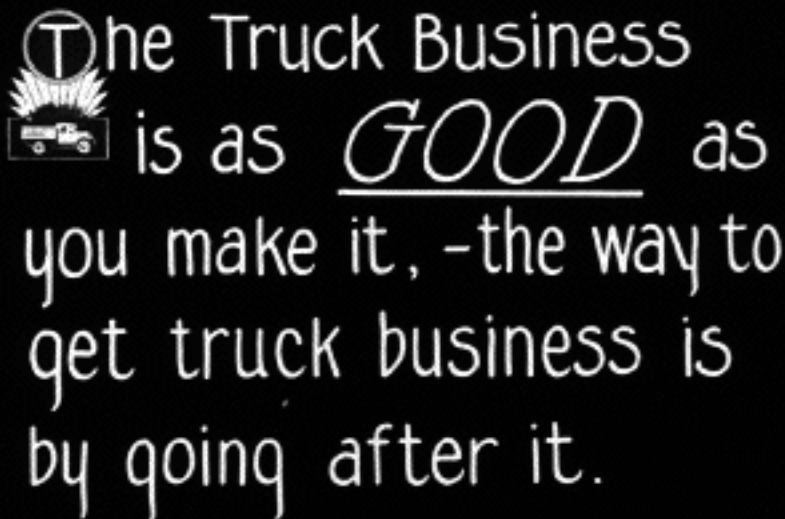

The Truck Business
 is as GOOD as
you make it, -the way to
get truck business is
by going after it.

3

"THERE'S MONEY IN TRUCKS."

 This film shows you
how Whippet and Willys
trucks answer to-day's
demand for lighter, more
flexible, more economical
trucks.

4

"THERE'S MONEY IN TRUCKS!"

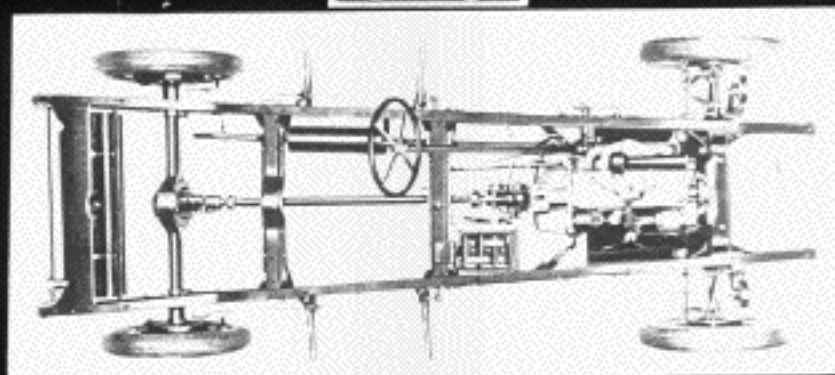

Now let us look at the Whippet
four cylinder chassis —
AS A TRUCK.

5

"THERE'S MONEY IN TRUCKS!"



4 Long Semi-Elliptic Springs

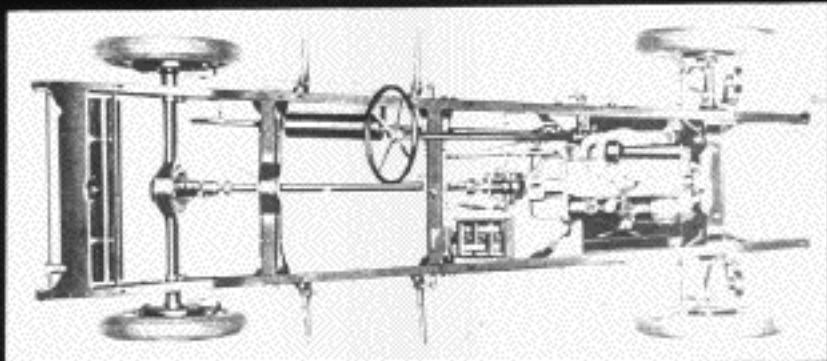

Full Length Frame
to support Body

Pressure Feed Lubrication
Strong Artillery Wheels

6

★ THERE'S MONEY IN TRUCKS. ★

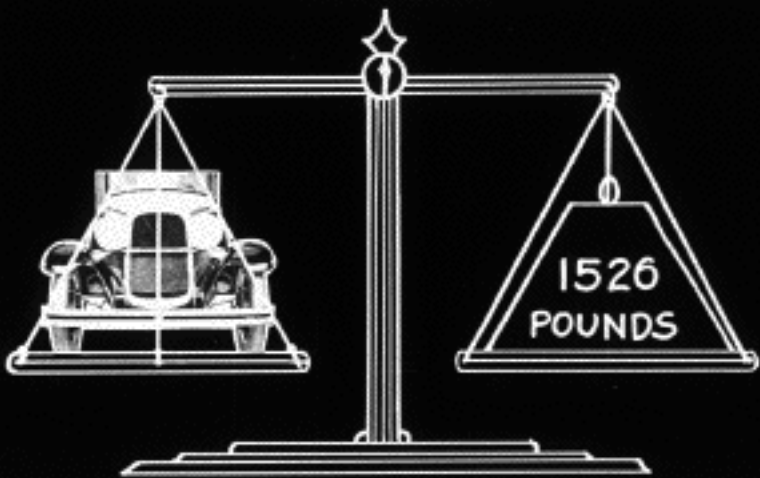

The rugged Whippet Chassis weighs 1526 pounds

7

'THERE'S MONEY IN TRUCKS.'

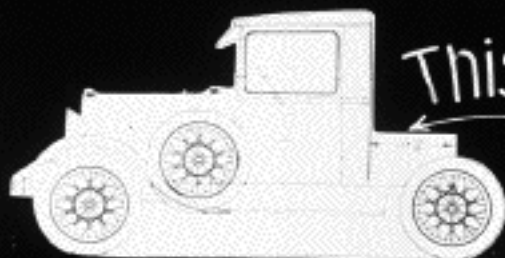

This or This



This Whippet frame supports the body throughout its length,—it is not bob-tailed, gives better balance, greater capacity.

8

'THERE'S MONEY IN TRUCKS.'

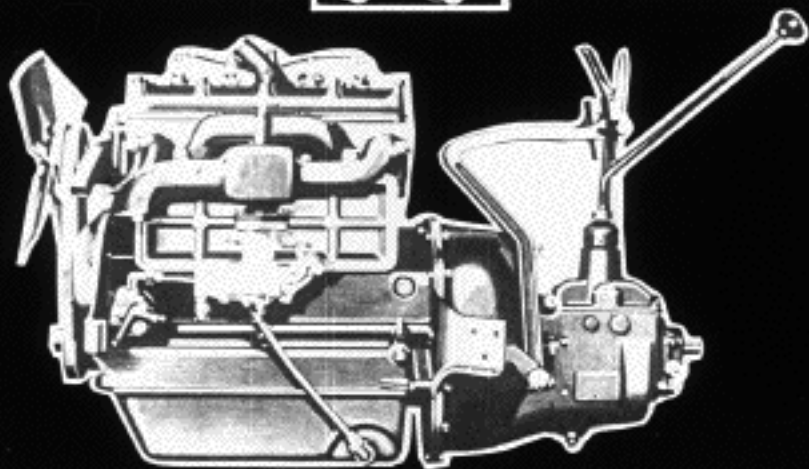

Hundreds of thousands of users endorse the Whippet motor as rugged, dependable, economical.

9

"THERE'S MONEY IN TRUCKS."

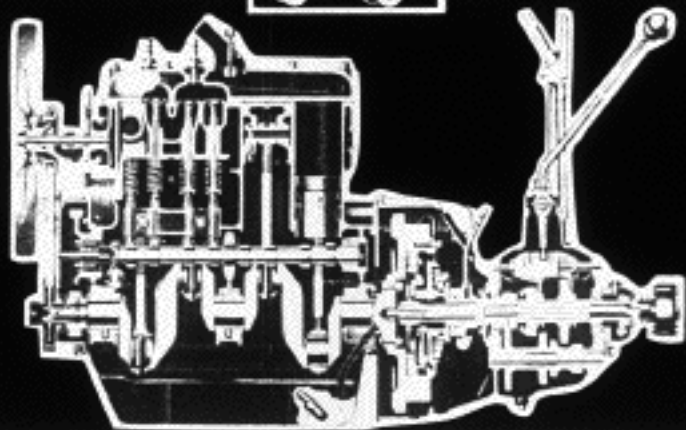

Quality features include--
Pressure Feed Lubrication
Extra Heavy Crankshaft
Close-fitting Pistons

Strictly Truck Parts
Long Stroke
Economy Manifolding
Adjustable Valves

10

'THERE'S MONEY IN TRUCKS.'

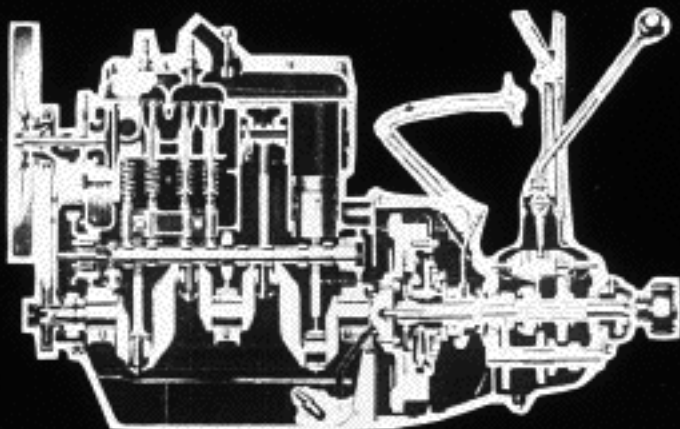

Heavy clutch and transmission with large nickel-steel gears assure long life and dependability. **11**

'THERE'S MONEY IN TRUCKS.'

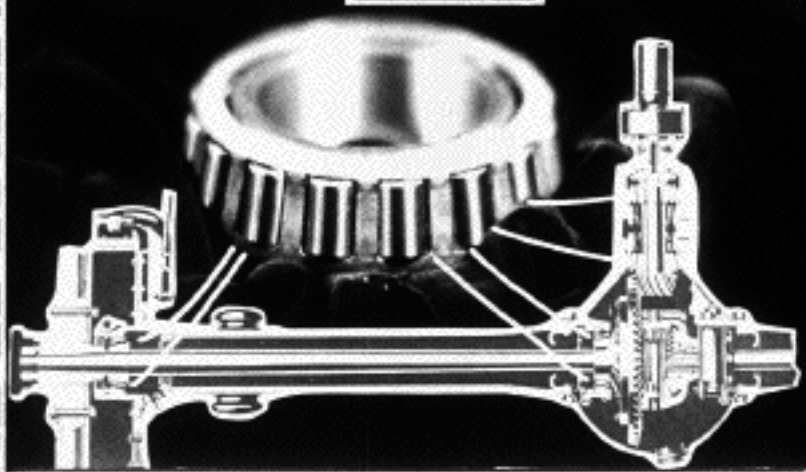

Money can't buy better quality than Timken Roller Bearings.—They are standard equipment in our commercial units.

12

"THERE'S MONEY IN TRUCKS."



The Whippet chassis is every inch a quality chassis for dependable, low cost commercial use...from initial investment as well as operation and maintenance.

13

"THERE'S MONEY IN TRUCKS."



If he carries $\frac{1}{2}$ ton loads,
the Whippet will do the job.

14

'THERE'S MONEY IN TRUCKS.'



A complete line of
bodies is available
through standard body
distributors
everywhere.

15

"THERE'S MONEY IN TRUCKS."

 Now let us look at the
Willys Six 1½ ton
truck—the size that an-
swers 74% of the entire
truck demand.

16

"THERE'S MONEY IN TRUCKS."

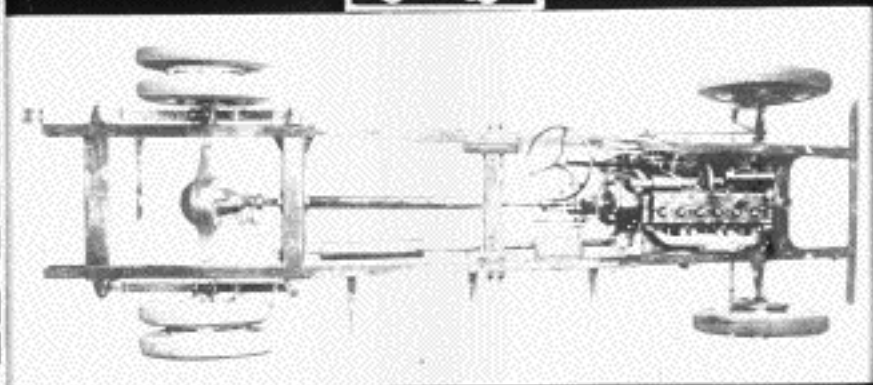

A TRUCK CHASSIS from front bumper to rear axle!

17

"THERE'S MONEY IN TRUCKS."

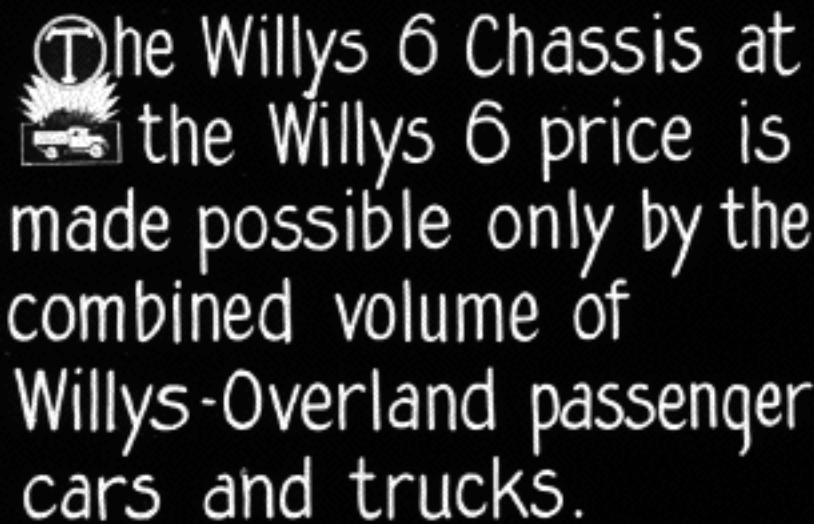

The Willys 6 Chassis at
 the Willys 6 price is
made possible only by the
combined volume of
Willys-Overland passenger
cars and trucks.

18

"THERE'S MONEY IN TRUCKS."

 No manufacturer who builds trucks exclusively can approach the Willys 6-1½ ton truck in side-by-side, dollar-for-dollar value.

19

"THERE'S MONEY IN TRUCKS."

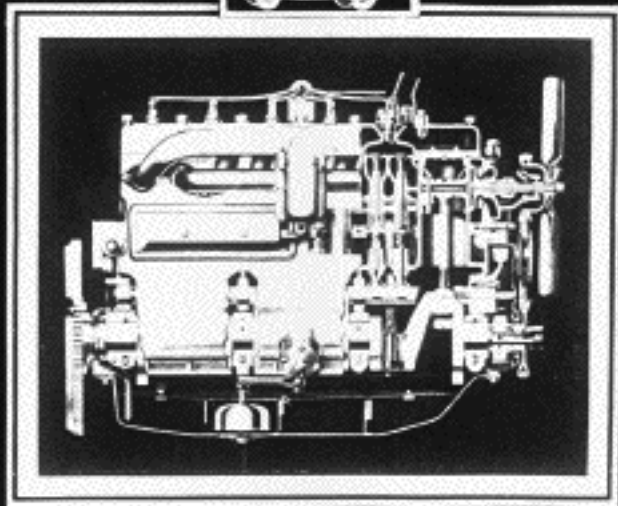

New and Brilliant performance is assured by
the abundant power of the Willys 6 motor.

20

'THERE'S MONEY IN TRUCKS.'



Willys Six trucks are
built of special truck
units to assure heavy
duty and satisfactory
operation at the lowest
possible cost to their owners.

21

"THERE'S MONEY IN TRUCKS."

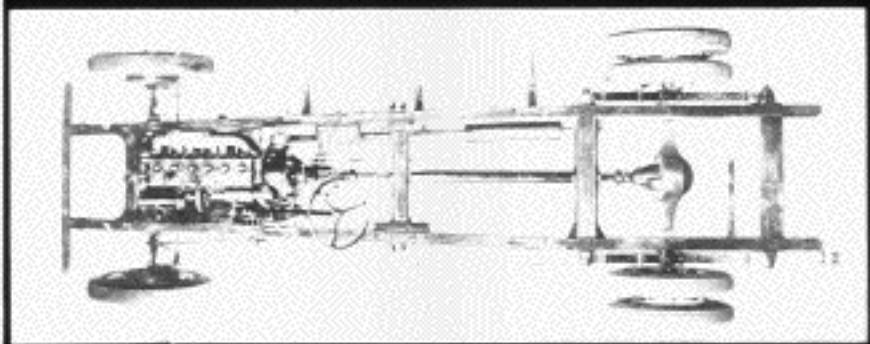

Heavy Frame is six inches deep: Tapered at front for short turning: cross members riveted to both flanges, making for extra rugged construction.

"THERE'S MONEY IN TRUCKS."

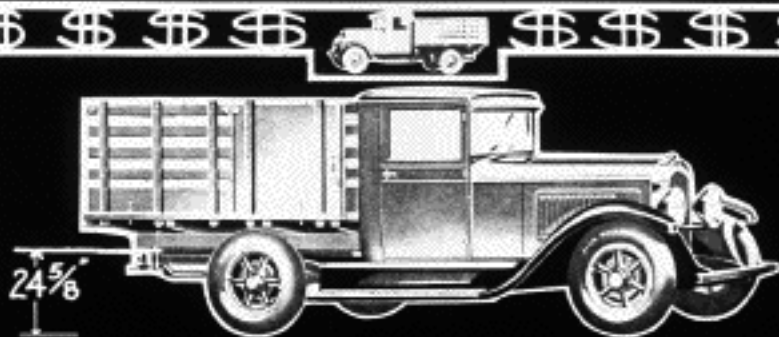

Frame is only $24\frac{5}{8}$ inches
above the pavement - saves
lifting - gives lower center
of gravity.

23

'THERE'S MONEY IN TRUCKS.'

 Four Speed

Transmission makes
it possible to combine
speed, power and
economy.

24

"THERE'S MONEY IN TRUCKS."

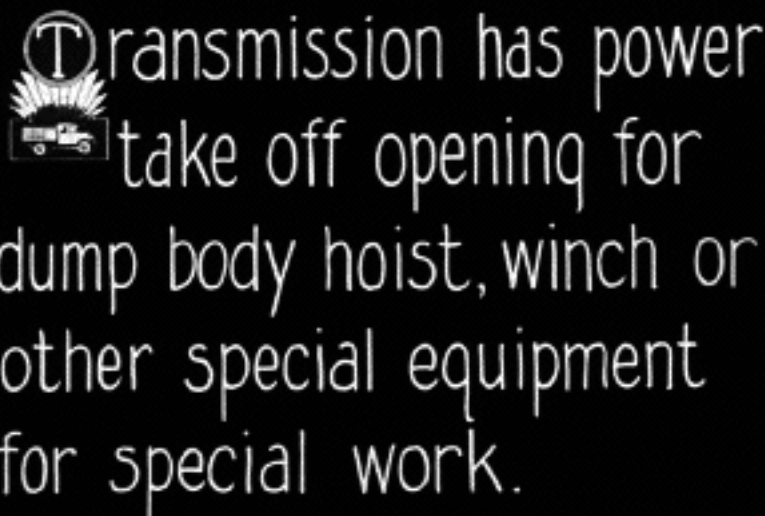

ransmission has power
take off opening for
dump body hoist, winch or
other special equipment
for special work.

25

"THERE'S MONEY IN TRUCKS."

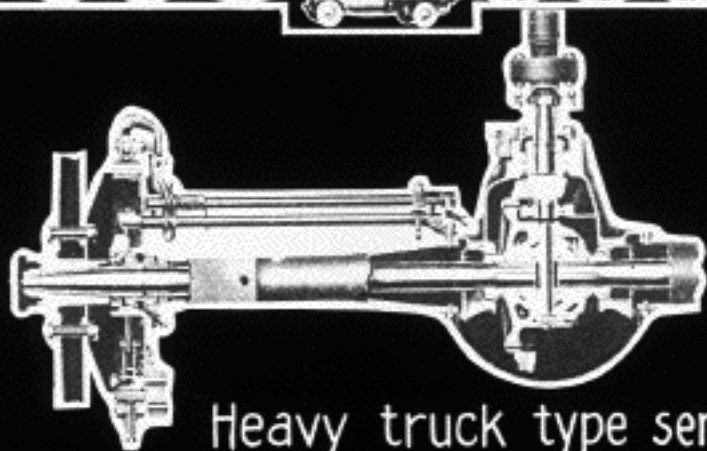

Heavy truck type semi-floating rear axle is built to carry the loads.

26

"THERE'S MONEY IN TRUCKS."

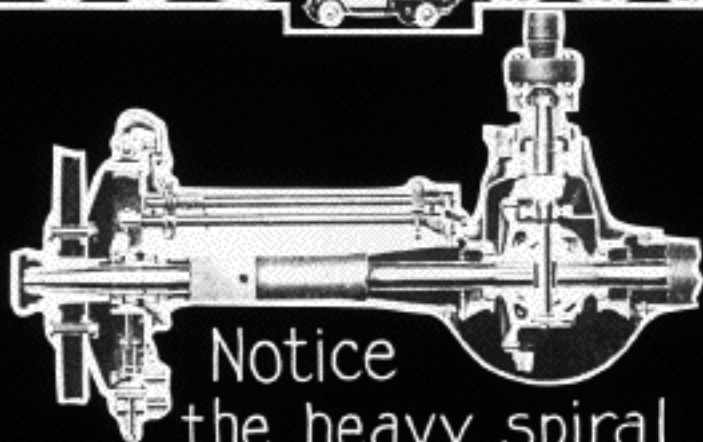

Notice
the heavy spiral
bevel gears with straddle
mounted pinion.

27

'THERE'S MONEY IN TRUCKS.'



 **F**our wheel internal expanding, cable control brakes afford adequate, positive deceleration under all driving conditions.

28

"THERE'S MONEY IN TRUCKS."



Men who know trucks
will O.K. the 9 leaf
front and 13 leaf rear
springs.



29

'THERE'S MONEY IN TRUCKS.'

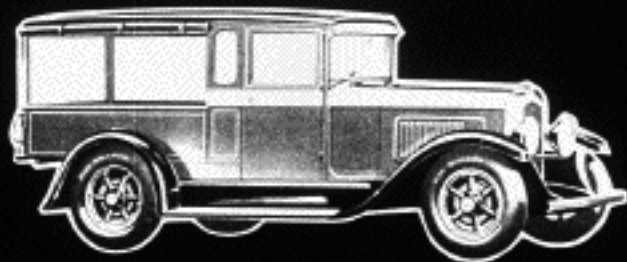

Truck type metal wheels
combine distinction and long
life, — one spare rim fits
all wheels.

30

"THERE'S MONEY IN TRUCKS."

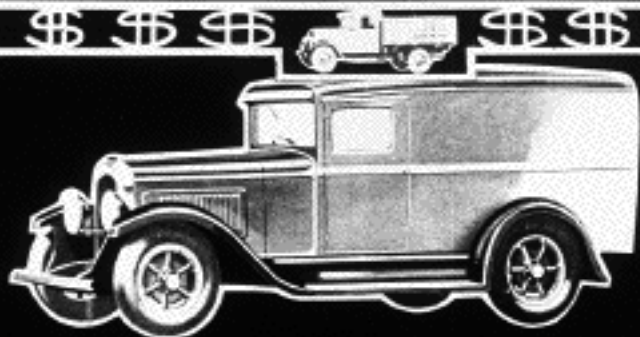

Notice the high radiator and smooth lines, - Willys Six trucks are good advertising for their owners.

31

'THERE'S MONEY IN TRUCKS.'



Finger tip control, 6 cylinder power and smoothness, electric starter, good appearance, make drivers proud of their Willys 6 trucks.

32

'THERE'S MONEY IN TRUCKS.'



The Willys 1 1/2 ton truck offers design far superior to cheap trucks, yet it costs hundreds of dollars less than others built by expensive small volume methods.

33

"THERE'S MONEY IN TRUCKS."



A Truck is known by the companies it serves.

34

'THERE'S MONEY IN TRUCKS.'



Repeat Orders are the proof of
the pudding in the truck business.

35

"THERE'S MONEY IN TRUCKS."

Men who need just one very economical truck
find that it's good business to choose the Willys 6.



36

'THERE'S MONEY IN TRUCKS.'



Men who know that truck cost is figured over the years are quick to appreciate the mechanical superiority of Whippet and Willys Six Trucks.

37

"THERE'S MONEY IN TRUCKS."

 Review the previous truck
films, to appreciate
seriously the truck market,
then remember how Whippet
and Willys 6 fit that market,
—then you'll see why there's
money in trucks.

38

"THERE'S MONEY IN TRUCKS."

COPYRIGHTED 1930 BY WILLYS - OVERLAND, INC.

The End
To rewind, start at this end dull side out holding film by edges. Be sure to keep fingers off dull side of film.

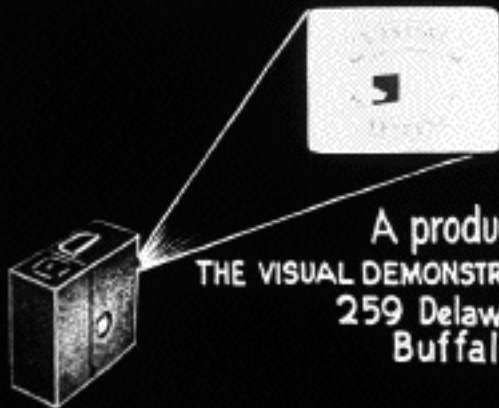

A production of
THE VISUAL DEMONSTRATION SYSTEM, Inc.
259 Delaware Ave,
Buffalo, N.Y.

Retail Sales Manager's Film Service.